

CNG Mobile Boost Compressor Trailer

Clean Energy provides mobile CNG boost compressor trailers that gives operators rapid, flexible, and cost-effective gas compression capacity on demand. Designed for field mobility and high performance, it enables pipeline pressure support, system bypassing, and emergency response without the expense or delays of fixed compression assets.

Key features:

- High-pressure compression capability
- Fully mobile
- 480 VAC motor-driven
- Gas detection and emergency shutdown
- Over-pressure and over-temperature protection
- Advanced control and monitoring
- Predictive maintenance and digital twin capability
- Rugged frame and vibration isolation
- Flexible connection options
- Noise reduction and environmental compliance
- Operational versatility
 - Pipeline support
 - System bypass during maintenance
 - Emergency outages
 - Boosting pressure for vehicle fueling
 - Temporary gas supply for industrial customers

Specifications:

- Inlets: 2 (high-pressure CNG trailer)
- Storage: 1 (high-pressure CNG trailer)
- Outlets: 2 (CNG dispenser connections)
- Voltage: 460 VAC 3ph, 60Hz
- Dimensions: 40'L x 102"W x 150"T

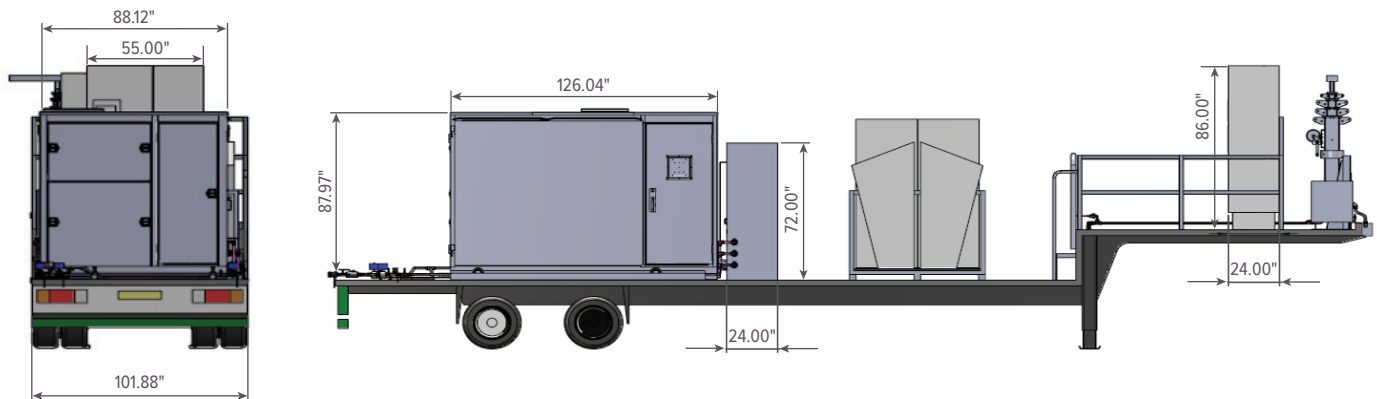
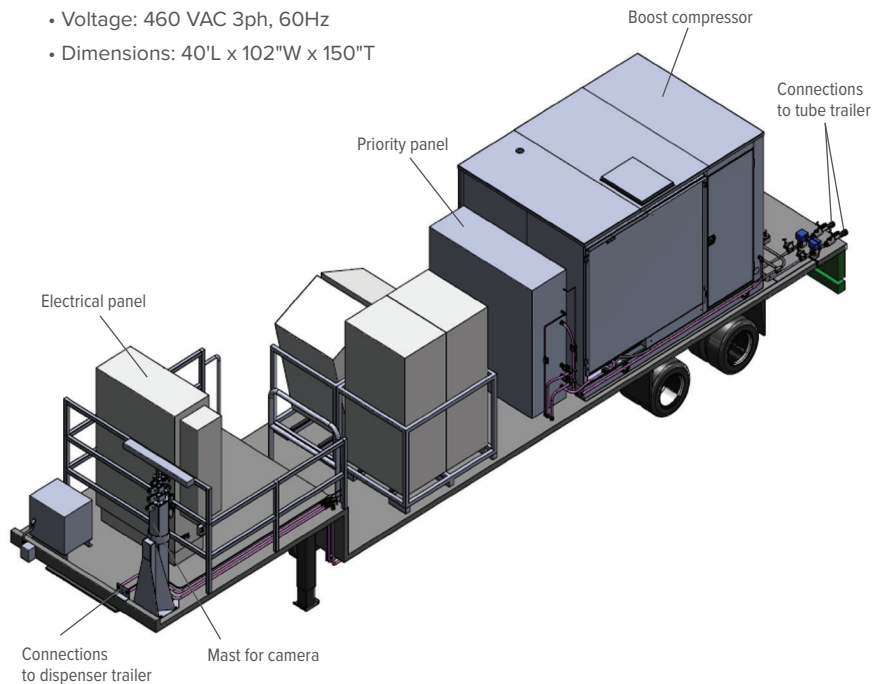

Greg Denton
Business Development Manager, Technologies
281.622.0406
gregory.denton@cleanenergyfuels.com

